



LT-800 DMX512 controller is the output signal of international standard DMX-512/1990. It not only can control all the LED lights that receiving the standard DMX signal in the market, but also can work with our DMX decoder to control the general LED lights without DMX512.

LT-800 DMX512 controller is easy to operate with a LCD screen. Available with wireless control and keying control on the changing modes, speed and brightness, automatic timing and more than 500 modes for your choices.

Product Parameter:

- **Working Voltage:** DC12 (with an adapter to convert AC100-240V to DC12V)
- **Power Consumption:** <2W
- **Output Signal:** DMX512
- **Output Loop:** 1 port
- **Transmission Speed:** 250Kbps
- **Lighting Mode:** 580 Modes
- **Control Quantity:** 512 DMX Channels (170 pixels)
- **Working Temperature:** -30°C to 65°C
- **Product Dimensions:** L163xW108xH40mm
- **Package Dimensions:** L260xW132xH46mm
- **Weight (G.W.):** 760g

Function Features:

- 1) With LCD screen, easy to operate in showing all functions.
- 2) Built-in perpetual calendar, real-time display system clock, can be set up to play different programs in any time, Monday to Sunday or holiday.
- 3) 680 lighting modes. Such as, 7 static color, skipping synchronism, smooth synchronism, color flow, color chasing, color smooth and flow and Meteor shower trailing, etc.
- 4) Multilevel changing speed, brightness, RGB grey scale adjustment and effect of movement direction for your choices.
- 5) Feel free to define many changing modes into a step, 8 independent cycle steps maximum.
- 6) Output with international standard signal DMX512/1990, can control 512 DMX channels (170 full color RGB pixels)
- 7) Support different output ports like standard XLR-3, RJ45 and Green terminals etc.
- 8) With the functions of anti-interference and automatic breakdown recovery.

Construction Drawing:

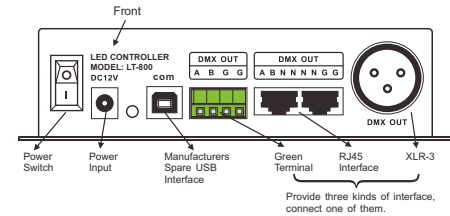
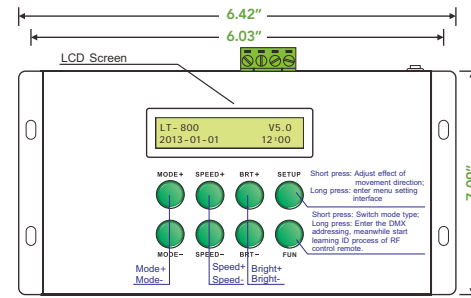

Controller (Receiver)

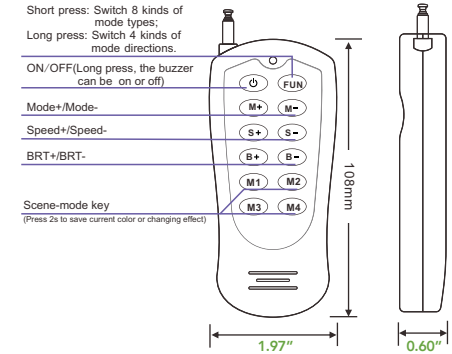

RF Remote Control

The Learning of RF Remote Control

Press the key "FUN" on the controller for 2 seconds, there is a buzzer sound, keep pressing the key.

Press any key on the remote control within 3 seconds, the controlling between remote control and the receiver is activated.

Press and key on the remote control over 3 seconds, the controlling between remote control and the receiver is cancelled.

Operating Instructions:

The controller has 8 function keys: **MODE+/MODE-(mode)**, **SPEED+/SPEED-(speed)**, **BRT+/BRT-(brightness)**, **SETUP(setup)**, **FUN (function)**

A. Basic Control

Pressing MODE+/MODE- button, to switch general change modes 1-30, automatic change modes 31-38 and automatic timing run change modes 39.

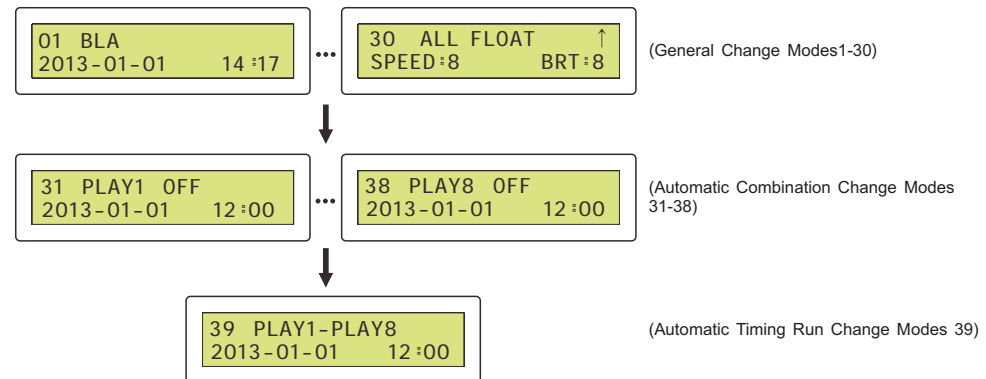

B. Operational Approach of General Change Modes 1-30:

01 BLA
2013-01-01 14:17

...

30 ALL FLOAT ↑
SPEED:8 BRT:8

(General Change Modes 1-30)

1) Following form is general change functional modes.

| NO. | Changing Color | Changing Type Choice | Movement Direction | Instruction | NO. | Changing Color | Changing Type Choice | Movement Direction | Instruction |
|-----|---|---|---|--|-----|---|------------------------|--|-------------|
| | Can be combined into 580 changing mode in total | | | | | Can be combined into 580 changing mode in total | | | |
| 1 | BLA ● | \ | \ | S P E E D / B R I G H T N E S S A D J U S T M E N T | 16 | R/P ●● | Press SETUP to Switch: | S P E E D / B R I G H T N E S S A D J U S T M E N T | |
| 2 | RED ● | Press FUN to switch: JUMP FLASH SMOOTH FADE FLOW CHASE METEOR FLOAT | Under the four modes: flow/chase/meteor/float, short press "SETUP" to switch: forward (↑) reverse (↓) close (⌘) split (⌘) | | 17 | G/Y ●● | | | |
| 3 | GRN ● | | | | 18 | G/C ●● | | | |
| 4 | BLU ● | | | | 19 | B/P ●● | | | |
| 5 | YLW ● | | | | 20 | B/C ●● | | | |
| 6 | PUR ● | | | | 21 | Y/P ●● | | | |
| 7 | GYN ○ | | | | 22 | Y/C ●● | | | |
| 8 | WHI ○ | | | | 23 | P/C ●● | | | |
| 9 | R/W ●○ | | | | 24 | R/G ●● | | | |
| 10 | G/W ●○ | | | | 25 | R/B ●● | | | |
| 11 | B/W ●○ | | | | 26 | G/B ●● | | | |
| 12 | Y/W ●○ | | | | 27 | R/G/B ●●● | | | |
| 13 | P/W ●○ | | | | 28 | Y/P/C ●●● | | | |
| 14 | C/W ●○ | | | | 29 | SIX ●●●●●● | | | |
| 15 | R/Y ●● | | | | 30 | ALL ●●●●●●○ | | | |

2) Submenu setting methods: at status of mode 1-30, press button SETUP for 3 seconds to enter submenu, see the form below.

| No. | Submenu Function (Press MODE+/- to Change Menu Below) | LCD Display Condition | Setting Methods |
|-----|---|---------------------------------------|--|
| 1 | PIXEL NUMBER CHOICE (range 004~170) COLOR PIXEL LENGTH CHOICE (range 01~08) | PIXEL NUMBER :032 COLOR PIXEL : 01 | Press BRT+/- increase or decrease pixel quantity. Press SPEED+/- to switch between PIXEL NUMBER and COLOR PIXEL. |
| 2 | OPERATION TIMES CHOICE (range 000~255) | RUN TIMES :255 000-NOT RUNNING | Press BRT+/- increase or decrease operation times (only work between mode 31-38) |
| 3 | RGB OUTPUT GREY LEVEL CHOICE (127~255 per RGB) (The white of mode 8 is made from RGB 0 ~ 255) | RGB BRIGHT ADJ R255 G255 B255 | Press BRT+/- to adjust each RGB level, press SPEED+/- to change R, G, or B (This feature with caution, 255 steps per default value RGB.) |
| 4 | MODE RECOVER DEFAULT | LOAD DEFAULT SET PRESS BRT+ - KEY | Press BRT+/- restore current mode default value |

Finish each parameter setting, then press button SETUP to exit.

C. Operational Approach of General Change Modes 1-30:

31 PLAY1 OFF
2013-01-01 12:00

...

38 PLAY8 OFF
2013-01-01 12:00

(Automatic Combination Change Modes 31-38)

When you are in 31-38 modes, press SETUP key for 3 seconds entering into the submenu such as below:

| No. | Submenu Function (Press MODE+/- to Change Menu Below) | LCD Display Condition | Setting Methods |
|-----|---|--|---|
| 1 | Setting switch state | 31 PLAY1 OFF OPEN1 SAVE1 | Press "BRT+/-" to set the switch state, Select "ON" to 39 automatic circle modes. |
| | Store the times of operating (convenient to set basic on the last time setting) | 31 PLAY1 OFF OPEN1 SAVE1 | Press "SPEED+/-" enter into "OPEN" (Turn out the operation times of 1-30 modes), then Press "BRT+" to confirm. |
| | Save the setting about the operation time | 31 PLAY1 OFF OPEN1 SAVE1 | Press "SPEED+/-" enter into "SAVE" (save the setting about the operation time), Press "BRT+/-" to confirm. |
| 2 | Setting operation week | RUN WEEK :MTWTFSS TIME :18:00-06:00 | Press "SPEED+/-" then you can see the "MTWTFSS"(Monday to Sunday) and 00:00 00:00(time), press "BRT+/-" to choose(if you do not choose the Monday to Sunday, the screen will appear _ the one mark) |
| 3 | Operate time and date 1 | DATE01 :0101-0103 TIME :00:00-00:00 | press "SPEED+/-" to change the "0101-0103(date)" or "00:00-00:00(time)"; Press BRT+/- to adjust the date and the time |
| 4 | Operate time and date 2 | DATE01 :0101-0103 TIME :00:00-00:00 | press "SPEED+/-" to change the "0101-0103(date)" or "00:00-00:00(time)"; Press BRT+/- to adjust the date and the time |
| 5 | Operate time and date 3 | DATE01 :0101-0103 TIME :00:00-00:00 | press "SPEED+/-" to change the "0101-0103(date)" or "00:00-00:00(time)"; Press BRT+/- to adjust the date and the time |
| 6 | System clock setting | DATE/TIME SETUP 2013-01-01 12:00 | Press "SPEED+/-" to choose "2013-01 01"(date), 12:00(time), press "BRT+/-" to adjust date and time. |
| 7 | RGB sequence setting | RGB ORDER : RGB | Press "BRT+/-" to adjust the RGB brightness sequence, for example: RGB, RBG, GRB, GBR, BRG, BGR. |
| 8 | Modes restore default value | LOAD DEFAULT SET PRESS BRT+ - KEY | Press "BRT+/-" restore the automatic default value. |

Press "SETUP" to exit after parameter setting.

D. Automatic Timing Run Mode 39:

When set to the 39th mode, according to the preset switch condition and running time of automatic change modes 31-38 to run the corresponding mode. The submenu only has the items that restore to default status (Please carefully choose this item).

Connection Schemes:

1) Connect to the LED lamps with DMX chip inside:

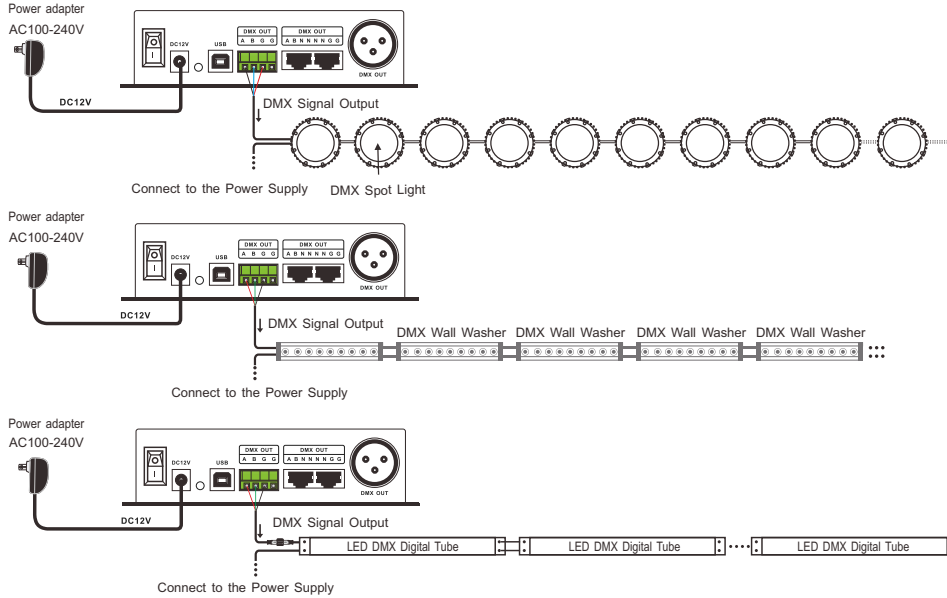

[NOTE] Please confirm the LED lamp you connected can receive standard DMX512 signal, otherwise it can't work properly.

2) Connect the DMX driver:

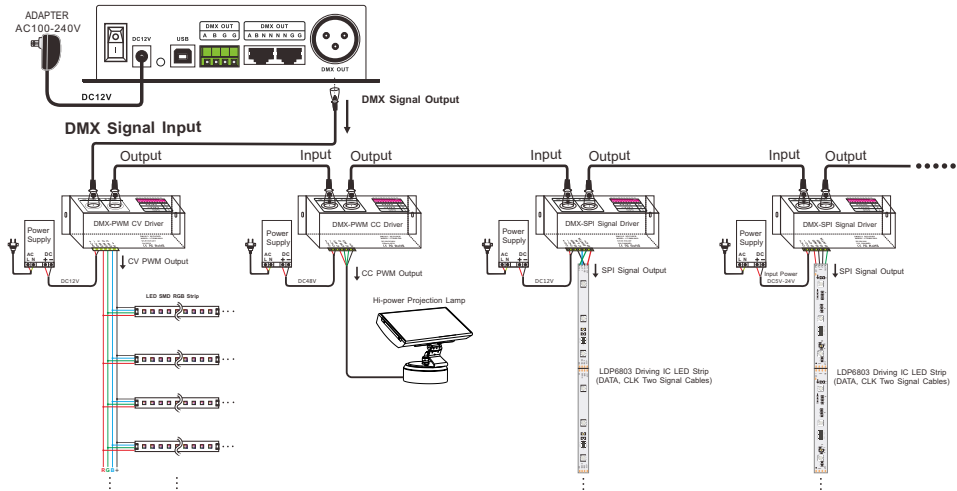

Additional Feature: DMX Address Writer:

[NOTE] DMX address writing applies only to our DMX lighting, if you use out LT-800 to control the DMX lights from other companies, please use their coordinated address writer only.

Instructions for use: Long press FUN button for 3 seconds, the controller automatically enter the DMX address writing mode, displaying as following:

| No. | Submenu Function (Press MODE +/- to Change Menu Below) | LCD Display Condition | Setting Methods |
|-----|---|--|---|
| 1 | DMX Address Reading Function | READING ADDR :000 REP :00 | Enter the menu, the controller automatically reads and displays the first address and actual pixel for current connected DMX lighting. REP display as 01,02,04,08,16, means the distribution of pixels of the lamps is 16,8,4,2,1 pixels respectively. For example, the lamps assigned to 8 pixels, the REP reads 02. |
| 2 | DMX Address Writing Function (to support the address writing for single lamp) (to support the address writing for multiple lamps) (to support the same of the first address of each lamp) | WRITING ADDR :001 REP :01 STEP :48 | Press SPEED +/- to switch three parameters, press BRT +/- to change the value. WRITING ADDR: Write the first address of the DMX lighting, the default is 001. REP: Write the actual pixels, the default is 01, means the lamps assigned to 16 pixels. STEP: Fill in the plus&minus step when set the "WRITING ADDR", the default is 48, meaning each plus&minus step is 48 for the first address. 1. When writing address for each lamp individually, use the "step" can quickly modify the first address of each lamp. 2. When multiple lamps in series connection and set the "REP" as 01,02,04,08,16, each lamp is assigned 16,8,4,2,1 pixels individually, the first address of each lamp will increase progressively. For instance, set the "WRITING ADDR" as 001," REP as 02, then the first address of each lamp is 001,025,049 in sequence, each lamp is assigned 8 pixels. 3. When multiple lamps in series connection and set the "REP" as 01S,02S,04S,08S,16S, each lamp is assigned 16,8,4,2,1 pixels individually, set the same first address for all lamps. For instance, set the "WRITING ADDR" as 001," REP" as 02, then the first address of all lamps together is 001, each lamp is assigned 8 pixels. |
| 3 | The DMX address testing verification | TESTING ADDR :001 VAL :255 STEP :48 | TESTING ADDR: fill in the test address value. VAL: fill in DMX value from 0 to 255 in the testing address, default is 255. for the other DMX address, the date sent is 0. STEP: fill in the plus&minus step when set the "WRITING ADDR", the default is 48, meaning each plus&minus step is 48 for the testing address. |

Attention:

- 1) The product shall be installed and serviced by a qualified person.
- 2) This product is non-waterproof. Please avoid the sun and rain. When installed outdoors please ensure it is mounted in a water proof enclosure.
- 3) Good heat dissipation will prolong the working life of the controller. Please ensure good ventilation.
4. Please check if the output voltage of any LED power supplies used comply with the working voltage of the product.
- 5) Please ensure that adequate sized cable is used from the controller to the LED lights to carry the current. Please also ensure that the cable is secured tightly in the connector.
- 6) Ensure all wire connections and polarities are correct before applying power to avoid any damages to the LED lights.

Warranty Agreement:

- 1) We provide lifelong technical assistance with this product:
 - A 5-year warranty is given from the date of purchase. The warranty is for free repair or replacement and covers manufacturing faults only.
 - For faults beyond the 5-year warranty we reserve the right to charge for time and parts.
- 2) Warranty exclusions below:
 - Any man-made damages caused from improper operation, or connecting to excess voltage and overloading. The product appears to have excessive physical damage.
 - Damage due to natural disasters and force majeure.
 - Warranty label, fragile label and unique barcode label have been damaged.
 - The product has been replaced by a brand new product.
- 3) Repair or replacement as provided under this warranty is the exclusive remedy to the customer. We shall not be liable for any incidental or consequential damages for breach of any stipulation in this warranty.
- 4) Any amendment or adjustment to this warranty must be approved in writing by our company only.

*This manual only applies to this model. We reserves the right to make changes without prior notice.